



Electronic Touch Voltage Monitor

Kiepe EBW 201

Introduction

The Kiepe EBW 201 Touch Voltage Monitor is designed for usage in trolleybuses. It functionally replaces the previous "EIW Electronic Insulation Monitor".

Trolleybuses are built using a "double insulation" safety precaution. The effectiveness of the insulation distances is examined regularly by measurement during maintenance intervals. Undis-

covered pre-existing damages or the effects of moisture can worsen the condition of the insulation both short-term and /or temporarily when in use during passenger operation, and are difficult or impossible to detect by measurement during maintenance in the depot.

Here, the Kiepe EBW 201 Touch Voltage Monitor offers the advantage of additional permanent monitoring supple-

mentary to the stipulated insulation testing during passenger operation.

The method of measurement used for the Kiepe EBW 201 does not bridge any operational insulation distances. The small amount of cabling required makes the Kiepe EBW 201 especially suitable for the subsequent installation in vehicles which are already available.

Description

The Kiepe EBW 201 monitors the voltage between the vehicle chassis and the street surface. Passengers can bridge this voltage (touch voltage) especially when entering/leaving, (see Figure 1). Should the fault voltage between street surface and vehicle chassis reach certain specific (yet harmless) values, this is announced to the driver both acoustically as well as optically. The driver can then take the necessary measures for the passengers' safety. Additionally, a possibility of au-

tomatic intervention for the separation of the overhead lines is provided. The touch voltage detection system consists of the Kiepe EBW 201 Electronic Touch Voltage Monitor, the driver's controls and the 2 collector cables which are insulated and attached to the chassis.

One collector cable establishes the contact between road surface and the Kiepe EBW 201 input. The second collector cable is used for the testing of the system and for

the improvement of the contact to the road surface during operation.

For the mode of operation see schematic circuit diagram and explanations on the following page.

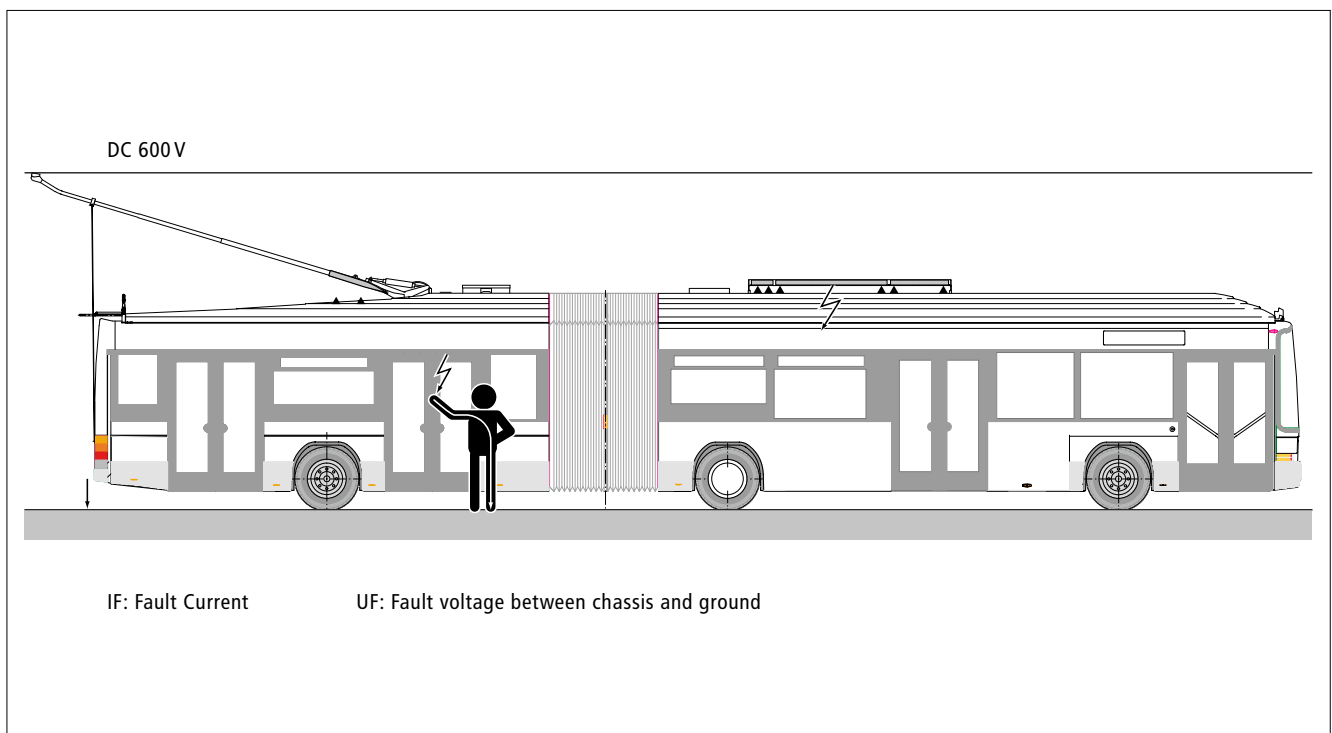

Figure 1

The Kiepe EBW 201 is supplied via an integrated, electrically insulated voltage supply from the DC 24V supply network.

The fault voltage between the chassis and the road surface is evaluated via a measuring circuit according to intensity and duration and controlled by the indicator panels. The evaluation of the fault voltage is carried out according to a characteristic curve as a function of intensity and duration (see Table 1).

The activation of the optical and acoustic signalling for the driver is carried out according to the dependency defined with the characteristic curve¹⁾ (Table 1). There are 3 warning levels (see Table 2).

¹⁾ Specifications are a guideline

Table 1: Evaluation of Fault Voltage

Fault voltage U (V)	700	400	300	200	100	70	< 40
Duration t (s)	0,1	0,2	0,4	0,6	1	5	10

Table 2: Warning levels and displays

Level	Fault voltage	Indicator light	Buzzer
0	< 30 V	Lamp 1 (white)	-
1	> 30 V	Lamp 2 (yellow)	short tone
2	> Characteristic Table 1	Lamp 3 (red)	continuous tone

Warning level 2 is stored in memory until it is reset by the driver (reset function). An automatic shutdown of the vehicle can occur via a free relay output (release function).

The necessary measures as a result of a warning message are defined through specific vehicle operator regulations.

The operating efficiency of the touch voltage monitor can be checked with the test function. On activation of the test function, an inadmissible fault

voltage is fed in and the correct reaction of the touch voltage monitor is checked. Good conductivity of the road surface should be available at the intended test location. A daily inspection of proper functioning is recommended.

The Kiepe EBW 201 is typically inserted close to the dashboard at the driver's seat and the operating and indicator elements are installed in the dashboard. The collector cables are mounted under the vehicle, insulated from the chassis. The lines from the collector

cables to the measuring input of the touch voltage monitor are to be selected which have the insulation necessary for the tension of the overhead lines.

Delivery includes solely the Kiepe EBW 201 Touch Voltage Monitor. Operating and indicator panels as well as collector cables and assembly materials can be obtained separately.

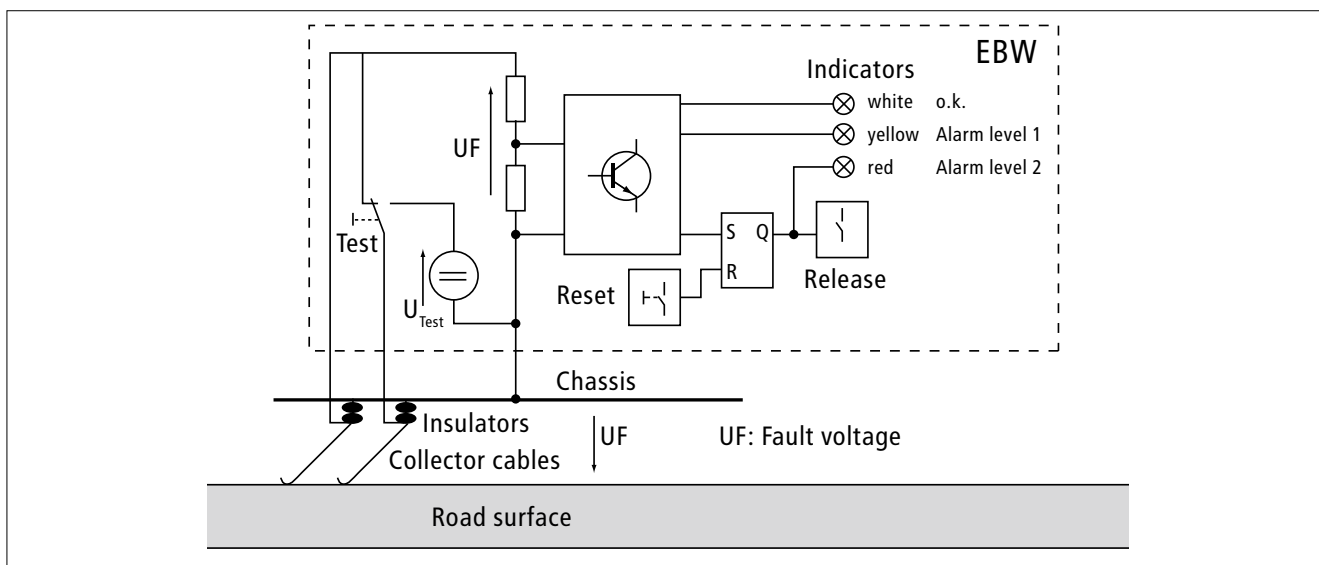

Technical data	
Supply voltage	DC 24 V +/- 30%
Operating temperature range	-25°C ... +70°C
Inputs	
- Controlling	Reset, Test
- Measurement input	Collector cable 1, Collector cable 2
Outputs	
- Signalling (Transistor/100 mA/24 V)	Stage 0, 1, 2, Buzzer
- Relay contact (N.O. contact / 100 mA/24 V)	Release
Connections	WAGO Clamp Series 257 and AMP-Metrimate
Dimensions (L x W x H)	approx. 110 x 110 x 90 mm
Mounting position	optionally
Mounting	EN 50022 top hat rail, G-Rail EN 50035
Degree of protection	IP 20
Weight	approx. 370 g
Tested according to	DIN EN 50155

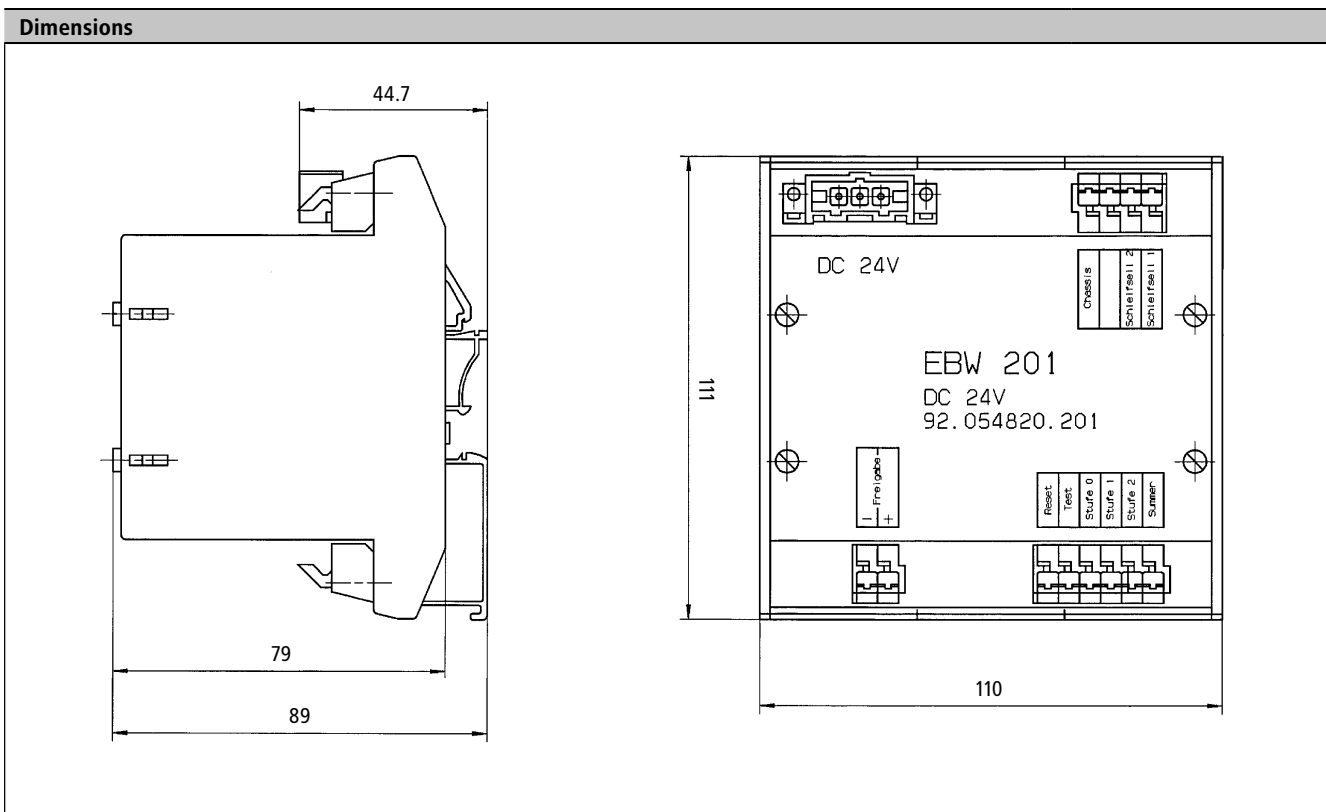

Dimensioned drawing for informational purposes only

Vossloh Kiepe GmbH
 Kiepe-Platz 1 • D-40599 Düsseldorf, Germany
 Telephone: +49(0)211/7497-0
 Telefax: +49(0)211/7497-300
 info@vkd.vossloh.com
 www.vossloh-kiepe.com

Subject to change without notice.